

Excavator Size (t)	A	B	Max Lift at Min Reach (kg)	Max Lift at Max Reach (kg)
	Max Reach Pin (m)	Max Reach Grab (m)		
20	11.3	11.3	8400.0	3250.0

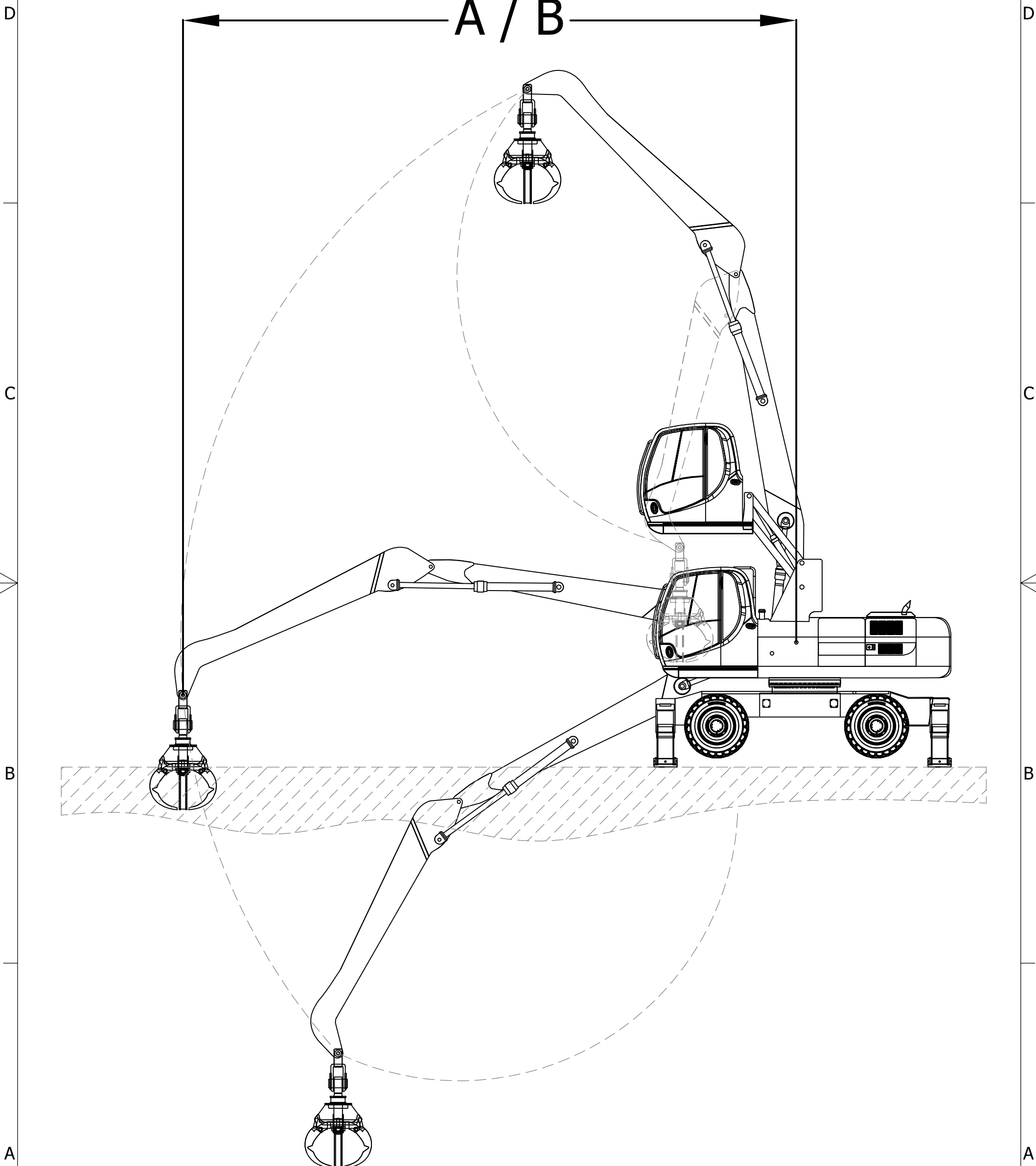

SHEET SIZE:	DRN:	THIRD ANGLE PROJECTION	NOT BINDING IN DETAIL
A3	CHKD:	DO NOT SCALE	All dimensions in mm U.N.O
The information contained within this document is the property of First Square Ltd and shall not be used or reproduced without given prior consent.			



DESCRIPTION:			
SCRAP HANDLING FRONT WORKING RANGE			
SCALE: 1:60	PART No: F-1020-FSQ-001	SHEET: 1 / 1	